

PCAN-PC/104-Card



Hardware manual

Version 1.0

Those products which are named in the handbook, which at the same time have registered trademarks may not always be marked as such. The lack of the ® mark does not consequently mean that the product is freeware. Just as little can be placed on the basis of pending patents or protection of designs. It is expressly acknowledged, that the company PEAK-System Technik GmbH accepts no responsibilities for either guaranties, legal responsibilities or any liability for any consequential damage, which may arise from the use or contents of these handbooks. The rights are reserved to alter without prior permission, information contained in the handbook. The company PEAK-System Technik GmbH accepts no liabilities whatsoever.

Furthermore it is expressly acknowledged, that PEAK-System Technik GmbH accepts no responsibilities either for guaranties or legal responsibilities or any liability for any consequent damage, which may arise from any misuse of the hardware. The rights are reserved to alter without prior permission, the layout or design of the hardware. PEAK-System Technik GmbH accepts no liabilities whatsoever.

© Copyright 1999 PEAK-System Technik GmbH- All rights reserved.

No parts of these books may be reproduced, processed, duplicated, transmitted or stored under any retrieval system, in any form without the written consent of the company PEAK-System Technik GmbH

PEAK-System Technik GmbH
Benzweg 4
D-64293 Darmstadt
Germany

Tel.: +49 6151 / 8173 20
FAX: +49 6151 / 8173 29
URL: <http://www.peak-system.com>
E-mail: Info@peak-system.com

1st Release March 2000

Contents

- 1. Overview 1
- 2. Application possibilities 1
- 3. Commissioning 1
 - 3.1 Connecting to the CAN-nets..... 2
 - 3.2 Arrangement of the address areas of the CAN-controllers..... 3
 - 3.2 Selection of the interrupt leads 3
 - 3.2.2 Settings for supply voltage through the SUB-D plug 4
- 4 The program CANVIEW 5
 - 4.1 Program configuration 5

1. Overview

- PC/104 „stackthrough“ module for PC/104 computer systems.
- Equipped with one or two (optional) PHILIPS CAN-controller SJA1000 with 16 MHz clock.
- Supports the interrupt leads IRQ3, IRQ5, IRQ7, IRQ10 – IRQ12, IRQ15.
- Transfer rates up to 1 MBit/s.
- Hardware reset of the SJA1000 from software commands is possible.
- Shared interrupt through the use of more cards in a PC.
- Connection via 9 pole SUB-D. Connected according to CiA-recommendation DS 102-1.

2. Application possibilities

The PCAN-PC/104-CAN-Card enables the direct connection of PC/104 computer systems and compatible systems to the CAN-bus. The card is normally equipped with one CAN-controller. Optionally, the card is also available with two CAN-controller. The connection to the CAN-bus is via 9 pole SUB-D plug manufactured to CiA-recommendation DS 102-1.

The registers of the CAN-controllers are directly addressed via the I/O-area of the PC.

3. Commissioning

The most important connectors and jumpers are shown in fig. 1.

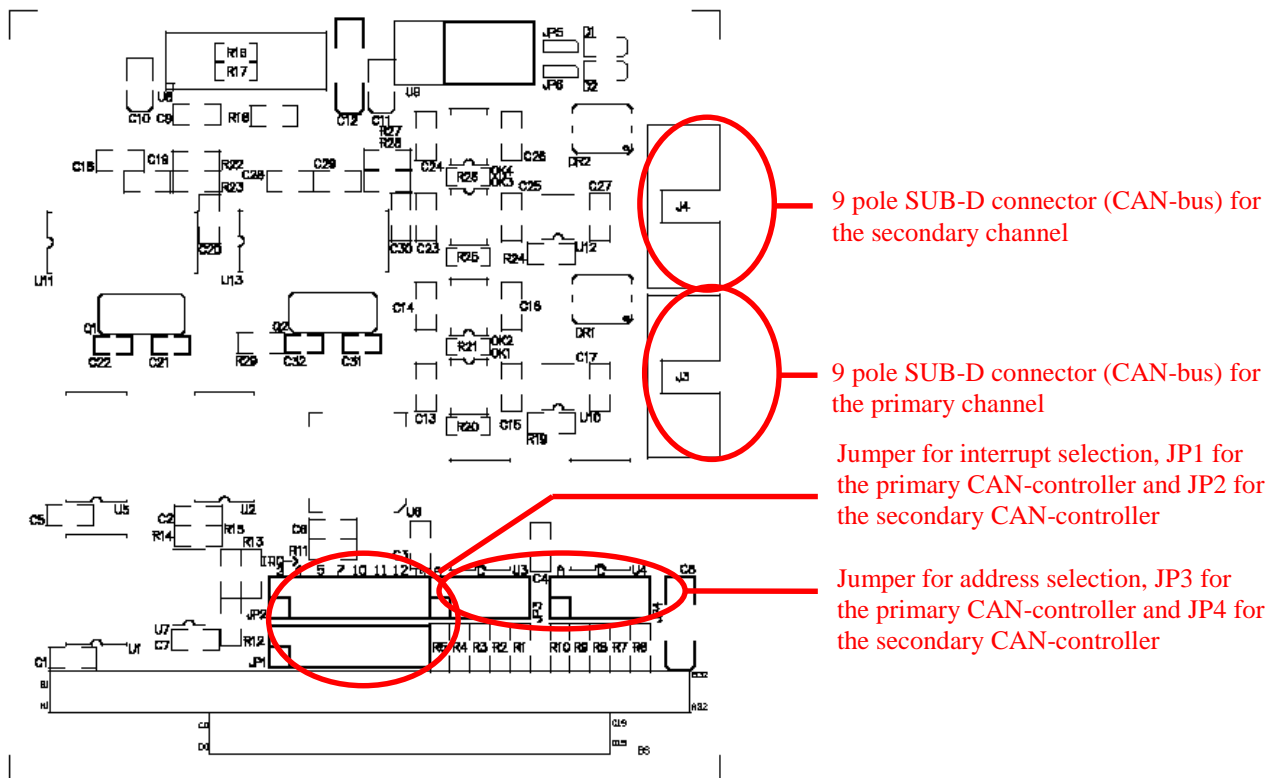

Fig. 1: Diagram of the most important connectors

3.1 Connecting to the CAN-nets

The CAN-net are connected via a 9 pole SUB-D plug according to CiA-recommendation DS 102-1. Minimal configuration are the pins 2 and 7 (CAN-L, CAN-H).

Configuration of the SUB-D plugs according CiA-recommendation DS 102-1

The SUB-D plug on board corresponds to the CiA-recommendation. Reserved pins are not connected.

Pin	Connection
1	Not connected (reserved pin)
2	CAN-L (dominant low)
3	CAN-GND
4	Not connected (reserved pin)
5	Not connected
6	GND (connected with CAN-GND)
7	CAN-H (dominant high)
8	Not connected (reserved pin, error line)
9	CAN_V+ : corresponds with the component insertion and JP5 or JP6 : external power supply for galvanic isolation: +7 .. +12V input internal power supply with galvanic isolation: +5V

Table 1: Connector configuration of the 9 pole SUB-D plug

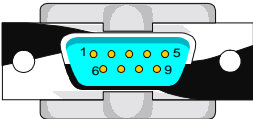

Fig.2 : Connector configuration of the 9 pole SUB-D plug

3.2 Arrangement of the address areas of the CAN-controllers

The PEAK-PC/104-CAN-Card connects for each CAN-channel 32 addresses to a selectable base address. The configuration of the I/O base address occurs with jumper field JP3 for the primary CAN-channel and with jumper field JP4 for the secondary channel. Table 2 shows the configuration settings (default setting: 300)-

Base address / pin	A	B	C	D	E
0x200...21F	X	--	--	--	--
0x220...23F	X	--	--	--	X
0x240...25F	X	--	--	X	--
0x260...27F	X	--	--	X	X
0x280...29F	X	--	X	--	--
0x2A0...2BF	X	--	X	--	X
0x2C0...2DF	X	--	X	X	--
0x2E0...2FF	X	--	X	X	X
0x300...31F	X	X	--	--	--
0x320...33F	X	X	--	--	X
0x340...35F	X	X	--	X	--
0x360...37F	X	X	--	X	X
0x380...39F	X	X	X	--	--
0x3E0...3FF	X	X	X	X	X

X ... jumper set
 -- ... no jumper set

Table 2: Configuration of the I/O base address

This table is also available at the backside of the module. So you can check the actual settings without this dokumentation.

3.2 Selection of the interrupt leads

The interrupt leads used are selected with the jumper field JP1 (primary CAN-controller) or JP2 (for the secondary CAN-controller). Fig. 3 shows the position of the jumper for the selection of IRQ 10 (default setting). It is also possible to run several PCAN-PC/104-CAN-Cards in a PC/104 computer system with the same interrupt (shared interrupt).

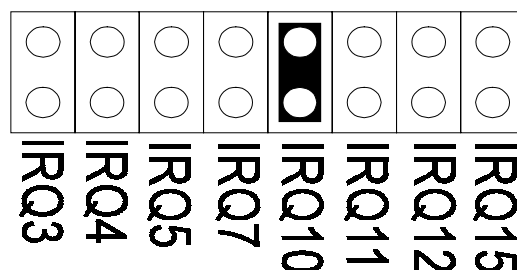

Fig. 3 Configuration of the used interrupts

The jumper position for the selected interrupt is also shown at the front- and backside of the module-

3.2.2 Settings for supply voltage through the SUB-D plug

With the soldered jumper JP5 (primary CAN-channel) and jumper JP6 (secondary CAN-channel) you can configure input- or output voltages to the 9 pole SUB-D plug corresponded with the component insertion.

It is not possible to use a galvanic isolated CAN-channel, which is external voltage supplied, *together* with an internal voltage supplied CAN-channel.

Never change the default soldering jumper without calling us at PEAK-System Technik GmbH.

The jumper position 1-2 determines, that a galvanic isolated channel will be external power supplied in a range between +7...+12 volts . But the jumper position 2-3 connects the internal power supply (5 volt) to pin 9 at the SUB-D plug. It is not allowed to connect all soldering jumper together (jumper position 1 and 2 with jumper position 3).

Do not connect jumper position 2 with 3, if other CAN-nodes also supply power to the plug.

The output voltage of PCAN-PC/104-CAN-Cards which were not galvanic isolated are unfused, the power is directly taken from the PC power supply unit!

The DC/DC converter from cards with galvanic isolated channels are not protected against overload!

By default, the jumper position 2-3 is not connected. Never change the default soldering jumper without calling us at PEAK-System Technik GmbH.

4 The program CANVIEW

Contained in the enclosed packet is the program CANVIEW which is a CAN-bus viewer under DOS. It supports various SJA1000 based PC-hardware expansions from PEAK-System Technik GmbH. It allows the sending and receiving of CAN-messages. It displays the basic software: the light-version of CANMON for DOS. With CANVIEW the current nets can be quickly examined and built up.

4.1 Program configuration

Start CANVIEW under DOS. Enter the base address of the PCAN-PC/104-CAN-Card and the interrupt. Select your desired baud rate. The PCAN-PC/104-CAN-Card is fully software compatible to the PC-ISA-CAN-Card. Select as hardware the PC-ISA-CAN-Card.

The card can be configured and connected to the CAN-net through the F10 button. If the error message „CAN-Controller not found“ is displayed, check the interrupt and port address used and then the selected hardware type.

Online help can be obtained at any time with the F! button.

CANVIEW										Hardware:		PC-ISA-CAN	
Empfangen													
Name	ID	Len	Daten [hex]					Anzahl	Zeit[s]				
	020	2:	00 64	--	--	--	--	1					
	02E	8:	00 64 00 64 00 00 80 AF					208	0.321				
	020	2:	00 64	--	--	--	--	1					
Senden													
Name	ID	Len	Daten [hex]					Anzahl	Zeit	Sollzt	Trigger		
	01E	5:	A7 00 FE 04 00	--	--	--	--	1		warten	User		
	023	1:	00	--	--	--	--			warten			
	025	1:	00	--	--	--	--	209	0.222	0.200	Time		
	020	2:	00 00	--	--	--	--			warten			
	021	2:	00 00	--	--	--	--			warten			
Fehler													
Fehlertyp	Anzahl	Zeit											
<F1> Hotkeys, <Strg-F1> Hilfe										(c) h&h'95			

Fig. 4 Screenshot of CANVIEWAbbildung